



ACTION[®]

Hammer Tools



Certificate

Standard **ISO 9001:2008**

Certificate Registr. No. 01 100 822 106232

The Certification Body of TÜV Rheinland Group certifies:

Certificate Holder:  **Action Tools Corp.**
No. 82, Lane 352, Kwang Fu Road, Kwang Fu LI,
Silun District, Taichung 40780, Taiwan, R.O.C.

Scope: **Design/Development, Manufacturing and Sales of Sockets,
Chisels and Tool Holders**

An audit was performed, Report No. 106232. Proof has been
furnished that the requirements according to ISO 9001:2008
are fulfilled.

The due date for all future audits is 16-03 (dd-mm)

Validity: **The certificate is valid from 2014-04-01 until 2017-03-31.
First certification 2011**

Taipei, 2014-04-22, rev. 1.0

TÜV Rheinland Taiwan Ltd.
11F, No. 758, Sec. 4, Suiho Rd.,
Taipei 105, Taiwan







Quality Management
QC9000

www.tuvdotcom.com
ID 9105063467

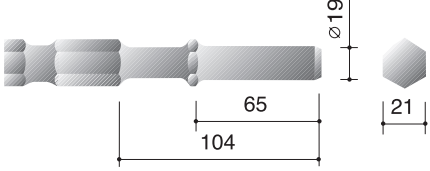
www.tuv.com

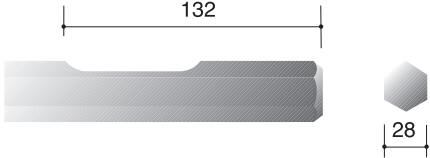
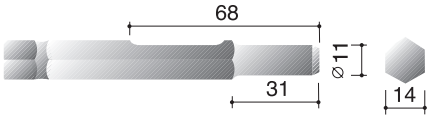
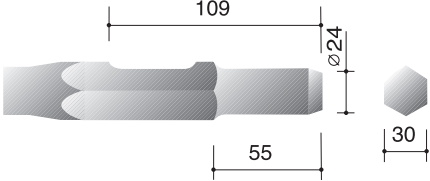
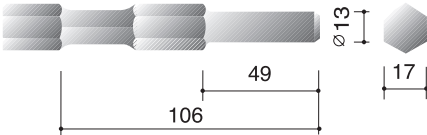
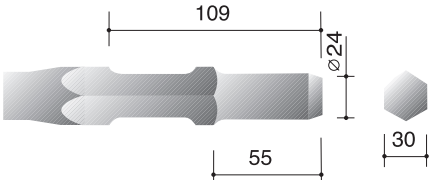
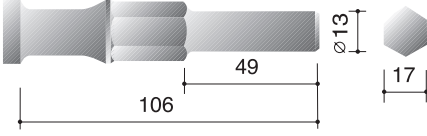
 **TÜVRheinland®**
Precisely Right.

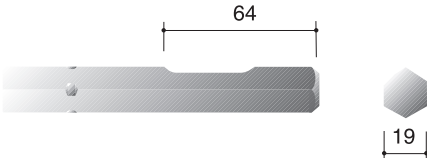
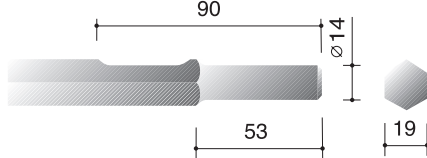
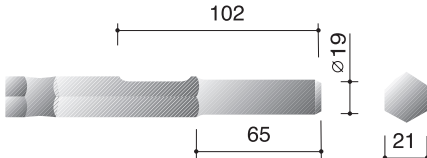
Shank No.	Shank For Electric Tools	Page	Shank No.	Shank For Electric Tools	Page
238		EH-01 EH-04	235		EH-17
239		EH-05 EH-09	237		EH-18
202		EH-10	226		EH-19 EH-21
204		EH-11	253		EH-21
224		EH-12	242		EH-22
206		EH-13	Accessories	Accessories For Power Tools	EH-23 EH-24
211		EH-14	Electric Hammer Cross Reference Guide		EH-25 EH-26
227		EH-15 EH-17			

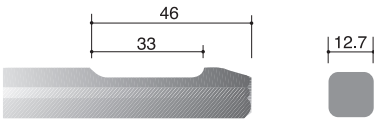
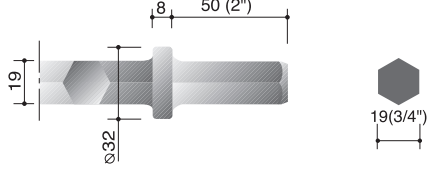
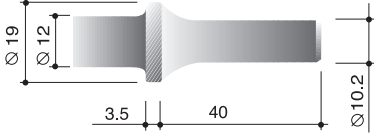
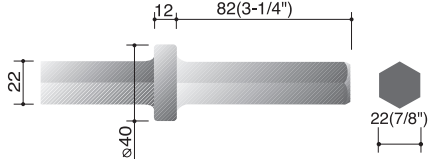
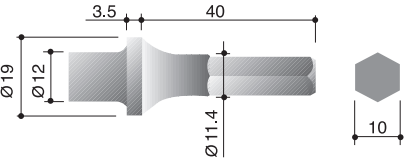
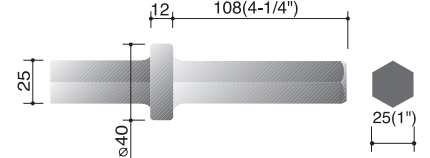
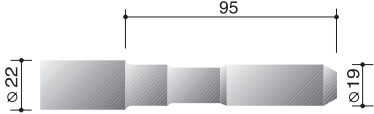
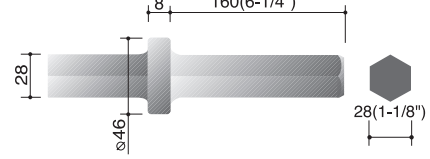
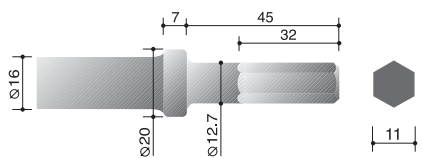
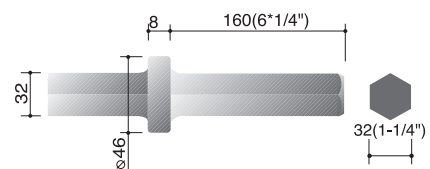
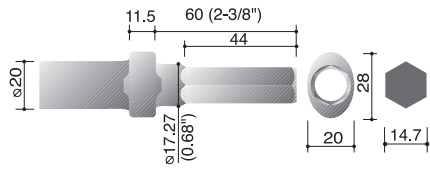
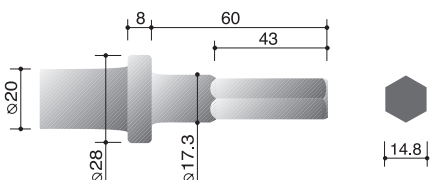
Shank No.	Shank For Pneumatic Tools	Page	Shank No.	Shank For Pneumatic Tools	Page
403		PH-01	131		PH-11
503		PH-02 PH-04	140		PH-12 PH-13
508		PH-05 PH-06	146		PH-14
186		PH-07	151		PH-15
164		PH-08	155		PH-16
127		PH-09	Pneumatic Hammer Cross Reference Guide		PH-17 PH-18
123		PH-10			





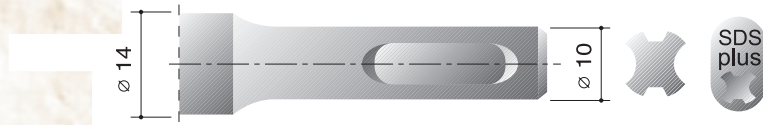





Shank No. 238



SDS-Plus is a registered trademark of Bosch









Shank: SDS-Plus

Working End	Part No.	Overall Length
		mm
Moil Point 	23801250	250
Flat Chisel 	23802250	250
40mm Wide Chisel 	23803250	250
40mm Wide Chisel, Bend 	23804250	250
22mm Hollow Gouge 	23805250	250
22mm Channel Chisel 	23806250	250
27mm Slotting Tool 	23807250	250
Brick Raking Chisel 	23808250	250
Slotting Tool with Carbide Tip 	23810150	150



SDS-Plus is a registered trademark of Bosch

Shank: SDS-Plus

Working End	Part No.	Working End	Overall Length
			mm
Slotting Tool with Carbide Tip 	23811250		250
75mm Wide Chisel 	23812165		165
75mm Wide Chisel, Bend 	23813165		165
Taper Punch 	23819160		160
Flat Chisel 	23820160		160
100mm Scraper Assembly 	23827270	Complete with 1.2mm thick Blade.	270
	23826270	Complete with 1.5mm thick Blade.	270
	23825270	Complete with 2.0mm thick Blade.	270
200mm Scraper Assembly 	23823270	Complete with 2.0mm thick Blade.	270
SDS-Plus Chisel Set 	P2380304	3 Piece SDS-Plus Chisel Set. Contents: 1-Moil Point (23801250) 1-Flat Chisel (23802250) 1-40mm Wide Chisel (23803250)	250















Shank No. 238



SDS-Plus is a registered trademark of Bosch









Shank: SDS-Plus

Working End	Part No.	Application	Overall Length
			mm
Drill Chuck Adaptor 	2380015	1/2"-20UNF With Screw 	62
1/4" Hex Bit Holder 	2380018	For 1/4" Hex Bits 	55
1/4" Sq. Adaptor 	2380043	With Steel Ball, To suit 1/4" dr., Sockets 	57
1/4" Sq. Adaptor 	2380044	With Locking Pin, To suit 1/4"dr., Sockets 	57
3/8" Sq. Adaptor 	2380051	With Steel Ball, To suit 3/8" dr., Sockets 	60
3/8" Sq. Adaptor 	2380054	With Locking Pin, To suit 3/8" dr., Sockets 	60



SDS-Plus is a registered trademark of Bosch

Shank: SDS-Plus

Working End	Part No.	Application	Overall Length
			mm
1/2", Sq. Adaptor	2380057	With Steel Ball, To suit 1/2" dr., Sockets	80
			
1/2", Sq. Adaptor	2380058	With Locking Pin, To suit 1/2" dr., Sockets	80
			
Quick-Release Bit Holder	2380065	For 1/4" Hex Power Bits	70
			
K-Taper Drill Holder	23809125		125
			
Core Drill Adaptor	2380152	External Thread M16,	110
	2380154	Inside Diameter of Central Hole Ø7.2mm	220
	2380156		300
	2380158		370
			









Shank No. 239



SDS-Max is a registered trademark of Bosch





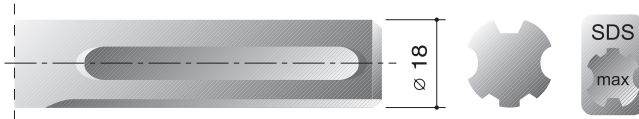

Shank: SDS-Max

Working End	Part No.	Overall Length
		mm
Moil Point 	23901280	280
	23901300	300
	23901360	360
	23901400	400
	23901460	460
	23901500	500
	23901600	600
Flat Chisel 	23902280	280
	23902300	300
	23902360	360
	23902400	400
	23902460	460
	23902500	500
	23902600	600
50mm Long Scaling Chisel 	23903400	400
50mm Wide Chisel 	23904300	300
	23904400	400
	23904450	450
50mm Wide Chisel, Bend 	23905300	300
	23905400	400
60mm Digging Chisel 	23906400	400
75mm Wide Chisel 	23907300	300
	23907400	400



SDS-Max is a registered trademark of Bosch

Shank: SDS-Max

Working End	Part No.	Overall Length
		mm
75mm Wide Chisel, Bend 	23908300	300
25mm Hollow Gouge 	23909300	300
33mm Hollow Gouge 	23910300	300
33mm Channel Chisel 	23911300	300
110mm Clay Spade 	23912500	500
135mm Pointed Spade 	23913550	550
115mm Wide Chisel 	23914350	350



Shank No. 239



SDS-Max is a registered trademark of Bosch

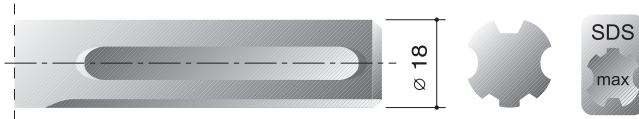

Shank: SDS-Max

Working End	Part No.	Overall Length
		mm
Adaptor for Floor Scraper 	23915400	400
27mm Mortar Chisel 	23916300	300
32mm Slotting Tool 	23917300	300
45mm Bushing Tool, Carbide 	23918250	250
125mm Asphalt Cutter 	23919500	500
45mm Bushing Tool 	23920240	240



SDS-Max is a registered trademark of Bosch

Shank: SDS-Max

Working End	Part No.	Overall Length
		mm
K - Taper Drill Holder 	23922180	180
	23922250	250
Ground Rod Driver 5/8" 	23923250	250
Ground Rod Driver 3/4" 	23924250	250
Snap Lock Adaptor for SDS-Plus Drill Bits 	23925220	220
Adaptor, Internal Thread Rd22 x P6.8 	23927200	200









Shank No. 239



SDS-Max is a registered trademark of Bosch

Shank: SDS-Max

Working End	Part No.	Working End	Overall Length
			mm
Slotting Tool with Carbide Tip 	23928280		280
Adaptor for E38 Tamper Plate 	23929300		300
Adaptor for E39 Tamper Plate 	23930300		300
Ground Rod Driver 1/2" 	23936250		250
Core Drill Adaptor 	2390152	External Thread M16, inside Diameter of Central Hole Φ 7.2mm	180
SDS-Max Chisel Set 	P2390301	3 Piece SDS-Max Chisel Set. Contents: 1-Moil Point (23901400) 1-Flat Chisel (23902400) 1-50mm Wide Chisel (23904400)	400

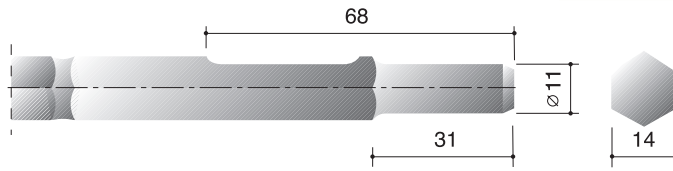
Shank: \varnothing 11x31 / \square 14mm







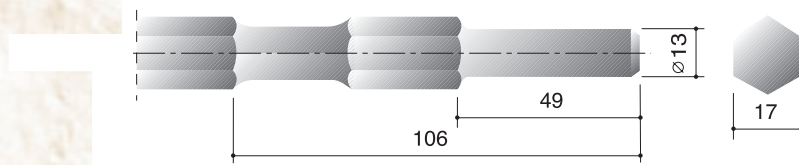



Working End	Part No.	Overall Length
		mm
Moil Point	20201300	300
	20201450	450
Flat Chisel	20202300	300
	20202450	450
40mm Wide Chisel	20203300	300
40mm Wide Chisel, Bend	20204300	300
50mm Wide Chisel	20207300	300
60mm Digging Chisel	20208400	400



Shank No. 204







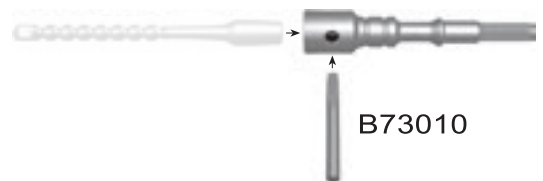

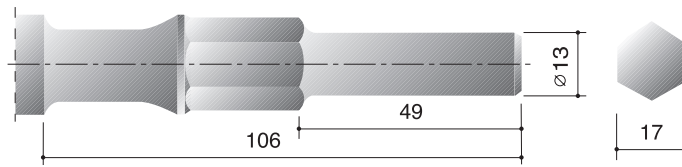
Shank: Ø 13x49 / 17mm

Working End	Part No.	Overall Length
		mm
Moil Point 	20401280	280
	20401360	360
	20401450	450
Flat Chisel 	20402280	280
	20402360	360
	20402450	450
50mm Wide Chisel 	20403280	280
	20403450	450
75mm Wide Chisel 	20405280	280
33mm Hollow Gouge 	20406300	300
22mm Hollow Gouge 	20407300	300
22mm Channel Chisel 	20408300	300
Slotting Tool with Carbide Tip 	20409320	320
110mm Clay Spade 	20410500	500
K-Taper Drill Holder 	24701175	175
Snap Lock Adaptor for SDS-Plus Drill Bits 	24702220	220



Shank: $\varnothing 13 \times 49$ / $\square 17$ / Body $\varnothing 22$ mm







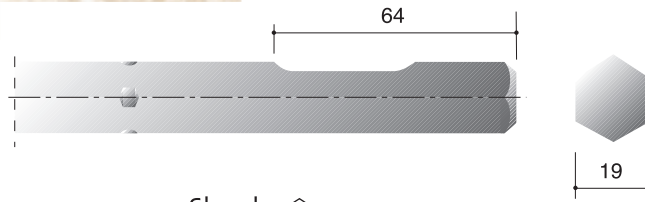

Working End	Part No.	Overall Length
		mm
Moil Point 	22401280	280
	22401300	300
	22401360	360
	22401450	450
Flat Chisel 	22402280	280
	22402300	300
	22402360	360
	22402450	450
50mm Wide Chisel 	22403300	300
75mm Wide Chisel 	22406300	300
	22406400	400
110mm Clay Spade 	22407500	500
135mm Pointed Spade 	22411550	550
Adaptor for E38 Tamper Plate 	22412320	320



Shank No. 206







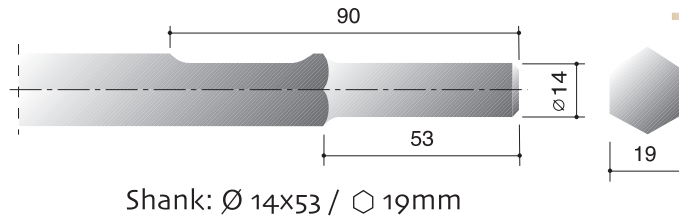

Shank: $\varnothing 19$

Working End	Part No.	Overall Length
		mm
Moil Point 	20601400	400
Flat Chisel 	20602400	400
50mm Wide Chisel 	20603400	400
75mm Wide Chisel 	20605300	300
Adaptor for E39 Tamper Plate 	20611300	300
Adaptor for Floor Scraper 	20612400	400
110mm Clay Spade 	20613500	500
115mm Wide Chisel 	20615450	450
125mm Asphalt Cutter 	20616500	500

Shank No. 211

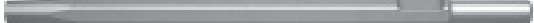





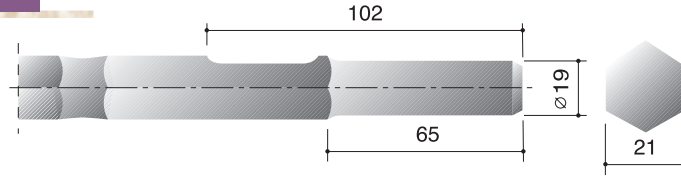

Working End	Part No.	Overall Length
		mm
Moil Point 	21101300	300
	21101380	380
	21101450	450
Flat Chisel 	21102300	300
	21102380	380
	21102450	450
	21102600	600
50mm Wide Chisel 	21103300	300
75mm Wide Chisel 	21104300	300
110mm Clay Spade 	21107500	500
Adaptor for Floor Scraper 	21108400	400
Snap Lock Adaptor for SDS-Plus Drill Bits 	24802220	220



Shank No. 227



Shank: Ø 19x65 / 21mm

Working End	Part No.	Overall Length
		mm
Moil Point 	22701300	300
	22701380	380
	22701400	400
	22701450	450
	22701600	600
Flat Chisel 	22702300	300
	22702380	380
	22702400	400
	22702450	450
	22702600	600
50mm Wide Chisel 	22703300	300
	22703400	400
	22703550	550
75mm Wide Chisel 	22704300	300
	22704380	380
	22704450	450
110mm Clay Spade 	22706500	500
135mm Pointed Spade 	22707550	550

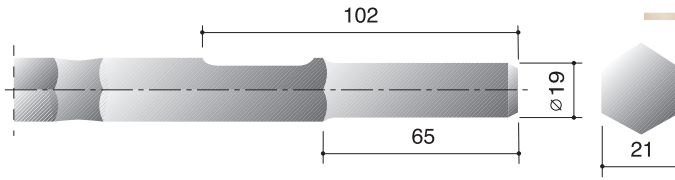

Shank: Ø 19x65 / 21mm

Working End	Part No.	Overall Length
		mm
Adaptor for Floor Scraper 	22709400	400
125mm Asphalt Cutter 	22712500	500
50mm Wide Chisel, Bend 	22713300	300
Adaptor for E38 Tamper Plate 	22716300	300
Adaptor for E39 Tamper Plate 	22717300	300
75mm Wide Chisel, Bend 	22718300	300
Ground Rod Driver 5/8" 	22720250	250
Ground Rod Driver 3/4" 	22721300	300



Shank No. 227

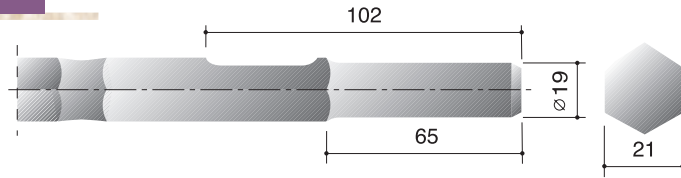

Shank: $\varnothing 19 \times 65$ / $\square 21$ mm

Working End	Part No.	Overall Length
		mm
Star Picket Driver 50mm 	22722250	250
Ground Rod Driver 1/2" 	22723250	250
Snap Lock Adaptor for SDS-Plus Drill Bits 	24402240	240



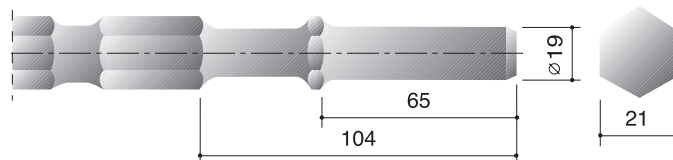



Shank No. 235

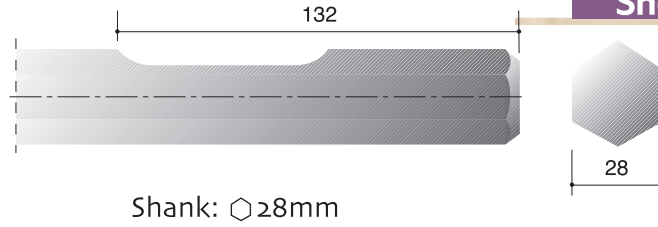

Shank: $\varnothing 19 \times 65$ / $\square 21$ mm (For free turning shank)

Working End	Part No.	Overall Length
		mm
Adaptor for Floor Scraper 	23509400	400
Adaptor for E38 Tamper Plate 	23516300	300
Adaptor for E39 Tamper Plate 	23517300	300







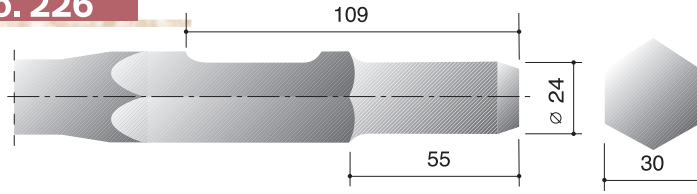

Working End	Part No.	Overall Length
		mm
Moil Point 	23701400	400
	23701500	500
Flat Chisel 	23702400	400
	23702500	500
75mm Wide Chisel 	23703400	400
125mm Asphalt Cutter 	23706500	500
60mm Digging Chisel 	23707450	450
Adaptor for Floor Scraper 	23708400	400
Adaptor for E38 Tamper Plate 	23710410	410



Shank No. 226



Shank: \varnothing 24x55 / \square 30mm

Working End	Part No.	Overall Length
		mm
Moil Point 	22601375	375
	22601410	410
	22601450	450
	22601550	550
Flat Chisel 	22602375	375
	22602410	410
	22602450	450
	22602550	550
50mm Wide Chisel 	22603450	450
75mm Wide Chisel 	22604410	410
110mm Clay Spade 	22605500	500
135mm Pointed Spade 	22606550	550
60mm Digging Chisel 	22607450	450

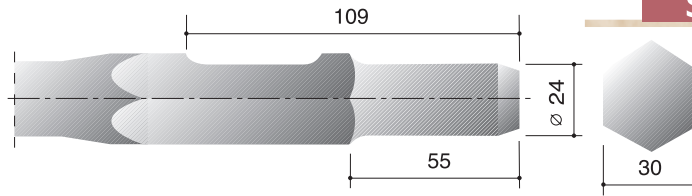

Shank: Ø 24x55 / 30mm

Working End	Part No.	Overall Length
		mm
Adaptor for Floor Scraper	22608400	400
125mm Asphalt Cutter	22609500	500
80mm Tie Tamper	22610720	720
Adaptor for E38 Tamper Plate	22611400	400
75mm Digging Chisel	22612500	500
50mm Bushing Tool	22613300	300
Star Picket Driver 50mm	22614200	200

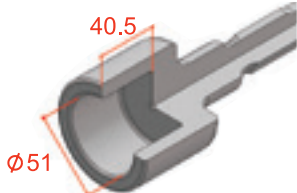



Shank No. 226

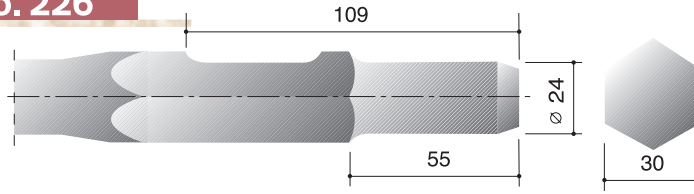

Shank: $\varnothing 24 \times 55$ / $\square 30$ mm

Working End	Part No.	Overall Length
		mm
Tent Peg Driver 50mm 	22615200	200
Ground Rod Driver 5/8" 	22616250	250
75mm Wide Chisel, Bend 	22617410	410
Post Socket Driver 55mm 	22618300	300
Star Picket Driver 80mm 	22619200	200



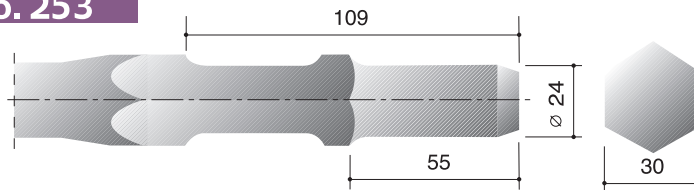



Shank No. 253

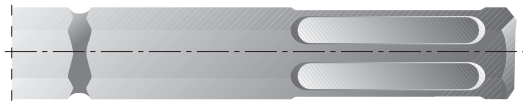







Shank: $\varnothing 24 \times 55$ / $\square 30$ mm
Same as 22604410 But 90°

Working End	Part No.	Overall Length
		mm
75mm Wide Chisel 	25301410	410

Shank: \hexagon 22.3 mm

Working End	Part No.	Overall Length
		mm
Moil Point 	24201360	360
	24201480	480
Flat Chisel 	24202360	360
	24202480	480
50mm Wide Chisel 	24203360	360
Adaptor for Floor Scraper 	24205400	400
110mm Clay Spade 	24209500	500
75mm Wide Chisel 	24211360	360

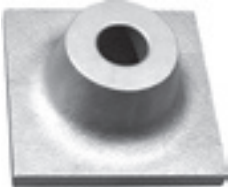
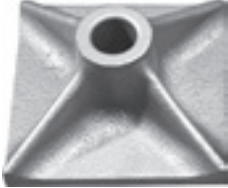
Working End	Part No.	Working End	Overall Length
			mm
Floor Scraper 	B61	Complete with 1.2mm x 150mm wide Blade	280
	B64	Complete with 1.5mm x 150mm wide Blade	280
	B65	Complete with 2.0mm x 150mm wide Blade	280
Blade 	B61020	1.2mm Blade for 150mm wide Floor Scraper	170
	B61080	1.5mm Blade for 150mm wide Floor Scraper	170
	B61090	2.0mm Blade for 150mm wide Floor Scraper	170
Repair Kit for B61/B64/B65 	B61040K	Contents- 4 x Bolts, M10 x 1.5 4 x Locknuts 8 x Washers 2 x Gaskets	
	B61040K-M12	Contents- 4 x Bolts, M12 x 2.0 4 x Locknuts 8 x Washers 2 x Gaskets	
Floor Scraper 	B69	Complete with 2.0mm x 150mm wide Blade	270
Repair Kit for B69 	B61190N	Service Kit Contents- 1 x 2.0mm x 150mm wide Blade 3 x Bolts, M12 x 1.25	
	B61140N	Screw Kit Contents- 3 x Bolts, M12 x 1.25	
	B61190	Blade 2.0mm x 150mm wide Blade	170

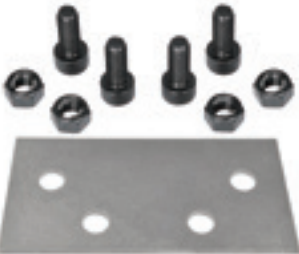
Working End	Part No.	Working End	Overall Length mm
Tamper Plate 	E38	150mm x 150mm	
Tamper Plate 	E39	125mm x 125mm	
Blade for SDS Plus Scraper 	A98020	1.2mm x 100mm wide Blade	95
	A98080	1.5mm x 100mm wide Blade	95
	A98090	2.0mm x 100mm wide Blade	95
Blade for SDS Plus Scraper 	A96090	2.0mm x 200mm wide Blade	95
Repair Kit for SDS Plus Scraper 	A96090K	Contents- 1 x Clamp Plate 4 x Bolts, M8 x 1.25 4 x Locknuts	



Electric Hammer Cross Reference Guide

Hammer Manufacturer	Shank No.	To suit Hammer Models	Page
AEG	238	APH14, PH210, PHE16, PHE19, PHE20, PHE24, PHE26	EH-01~EH-04
Atlas Copco	239 204 206 227 235 237	PH55, PHE-5S, PH-5S PH5F PB14D PB6C, PB10, PB10C, PB14C, PH11C PB6C, PB10, PB10C, PB14C, PH11C PB32B	EH-05~EH-09 EH-11 EH-13 EH-15~EH-17 EH-17 EH-18
BOSCH	238 239 206 237	11207, 11210, 11211, 11212, 11213, 11215, 11221, 11222, 11224, 11228, 11236, 11214EVS, 11216, 11223, 11227, 11230, 11231, 11235, 11309, 11311, 11312, 11313, 11316. 11245, GBH5, GBH5CE, GBH5/40DCE, GBH8DCE, GBH10/DC, GBH38, GSH4, GSH10C. 11302, 11305, 12312, USH10 11304, 11308, 12308, 12314, HSH10, HSH27, HSH28, USH27, GSH27	EH-01~EH-04 EH-05~EH-09 EH-13 EH-18
Black & Decker	238 239 237	5009, 5013, 5014, 5016, 5053, 5054, 5056, 5057 5097, 5099 5027	EH-01~EH-04 EH-05~EH-09 EH18
Dewalt	238 239 206	514K, 523K, 557K, 566K, 567K 541K, 545K 5021K, DW558K	EH-01~EH-04 EH-05~EH-09 EH-13
Elu	239 206 242	BH40/41EK, VH45/46EK, SH50EK SH60K TE905, TE55, TE805, TE1000AVR, TE1500AVR	EH-05~EH-09 EH-13 EH-22
Hilti	238 239	TE15C, TE24, TE25, TE104 TE54/52, TE-F52, 60, TE-F72, 92, TE-Y74, 75, TE76, TE-Y504, 505, TE-Y704, 705, TE42, TE55, TE60, TE72, TE74, TE75, TE92, TE504, TE704, TE104	EH-01~EH-04 EH-05~EH-09
Hitachi	238 239 204 224 206 227 235 237 226 151	DH22VB, DH22VD, VR16, VRT22, DH36DAL DH40MA, DH40MB, H45MA, H60MA, H60MB, DH45MR, DH40MR, HR45MR DH28Y, DH38YB, DH38YB1, DH42, H41, H45SA, PH40F, PHU45, PR25B, PR38E, VR38, VRY38YB DH28Y, DH38YB, DH38YB1, DH42, H41, H45SA, PH40F, PHU45, PR25B, PR38E, VR38, VRY38YB H55SC DH50SA, DH50SA1, H55SA, H55SC DH50SA, DH50SA1, H55SA, H55SC H65, H85, H90SB H65SA, PH65A, H65SB H90SB	EH-01~EH-04 EH-05~EH-09 EH-11 EH-12 EH-13 EH-15~EH-17 EH-17 EH-18 EH-19~EH-21 PH-15

Electric Hammer Cross Reference Guide







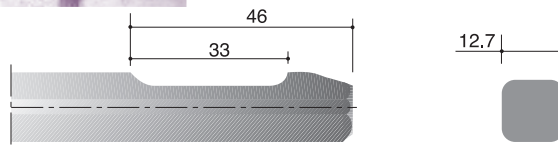

Hammer Manufacturer	Shank No.	To suit Hammer Models	Page
Kango	238	200, 285, 327, 422, 426, 430D	EH-01~EH-04
	239	710MV, 760MV, 810MV, 850FV, 900HV, 1400MV	EH-05~EH-09
	206	638S, 900B, 900KS, 900S, 900XS, 1400B	EH13
	211	450C, 500, 501, 625, 626, 627, 638, 750, 750X, 800X	EH-14
	227	900, 900X, 928, 950, 950K, 950X, 1400	EH-15~EH-17
	235	900, 900X, 928, 950, 950K, 950X, 1400	EH-17
Makita	238	HR160, HR1821, HR2000, HR2010, HR2400, HR2410, HR2420, HR2511	EH-01~EH-04
	239	HR500C, HM1100C, HM1100S, HM1200C, HR4000C, HR5001C	EH-05~EH-09
	204	8035NB, HM0810, HM0810T, HM1200, HR3500, HR3510, HR3520, HR3850, HM0830	EH11
	224	8035NB, HM0810, HM0810T, HM1200, HR3500, HR3510, HR3520, HR3850	EH-12
	206	HM1200B, HM1211B	EH-13
	237	HM1303B, HM1500B, HM1800	EH-18
	226	8900N, 8900-S, HK1300, HM0810T, HM1300, HM1303, HM1400, HM1500, HM1304	EH-19~EH-21
	151	HM1810	PH-15
Metabo	238	6010, 6018, 6020, 6024, 6026	EH-01~EH-04
	239	6045, Bh6045S	EH-05~EH-09
Milwaukee	238	5302, 5303, 5312, 5317, 5320, 5324, 5343, 5344, 5347, 5348, 5362, 5366, 5368, 5369	EH-01~EH-04
	239	5308, 5313	EH-05~EH-09
	206	5335	EH-13
	237	5338	EH-18
Ramset	238	425	EH-01~EH-04
	202	342	EH-10
Ryobi	238	ED160, ED211	EH-01~EH-04
	239	ER382K, DE382NP	EH-05~EH-09
	224	CH450PK, CH460PK, CH500K, CH500P, ER382K	EH-12
	226	CH500P	EH-19~EH-21
Wacker	239	EHB-7SM	EH-05~EH-09
	237	EH27	EH-18



Shank No. 403







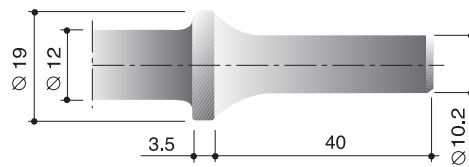



Shank: □ 12.7x46mm with 33mm Recess

Working End	Part No.	Overall Length
		mm
Moil Point 	40301155	155
	40301180	180
	40301450	450
19mm Flat Chisel 	40302155	155
	40302180	180
	40302300	300
	40302450	450
35mm Wide Chisel 	40303155	155
	40303180	180
	40303300	300
	40303450	450
35mm Wide Chisel, Bend 	40304155	155
	40304180	180
50mm Wide Chisel 	40305180	180
50mm Wide Chisel, Bend 	40306180	180
75mm Wide Chisel, Bend 	40308180	180
35mm Slotting Tool with Carbide 	40309150	150



Shank: $\varnothing 10.20(0.401") \times 40\text{mm}$ Taper Shank.







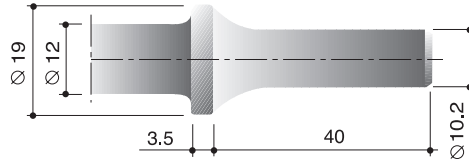

Working End	Part No.	Overall Length
		mm
32mm Scraper, Bend 	50302190	190
45mm Wide Chisel 	50303185	185
33mm Wide Chisel, Bend 	50304190	190
Taper Punch 	50305135	135
Spot Weld Breaker 	50306180	180
$\varnothing 12\text{mm}$ Straight Punch 	50308135 50308180	135 180
18mm Flat Chisel 	50309135 50309165 50309180	135 165 180
Bushing Splitter 	50310190	190
Spot Weld Breaker 	50311125	125



Shank No. 503



Shank: $\varnothing 10.20(0.401") \times 40\text{mm}$ Taper Shank.

Working End	Part No.	Overall Length
		mm
33mm Wide Chisel 	50312180	180
	50312230	230
$\varnothing 2.5\text{mm}$ Taper Punch 	50313180	180
Dual Blade Panel Cutter 	50314165	165
	50314180	180
Moil Point 	50315180	180
	50315200	200
	50315250	250
	50315350	350
28mm Tailpipe Cutter 	50316180	180
Spot Weld Breaker 	50317180	180
20mm Flat Chisel 	50318125	125
	50318180	180
	50318200	200
	50318250	250
	50318350	350
	50318450	450
Muffler Splitter 	50321175	175

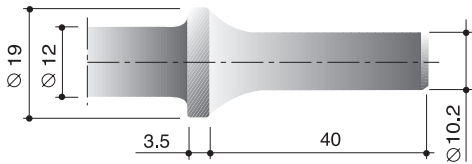

Shank: $\varnothing 10.20(0.401") \times 40\text{mm}$ Taper Shank.

Working End	Part No.	Overall Length
		mm
Single Blade Panel Cutter	50322125 50322180	125 180
Claw Ripper & Panel Cutter	50323135 50323180	135 180
Rivet & Bolt Cutter	50324165	165
50mm Wide Chisel	50327180	180
50mm Wide Chisel, Bend	50328180	180

Working End	Part No.	Working End
401 Shank Chisel Set	P5031001	10 Piece 0.401" Shank Air Chisel Set. Contents: 1-Chisel 50324165 1-Chisel 50318180 1-Chisel 50308180 1-Chisel 50313180 1-Chisel 50323180 1-Chisel 50310190 1-Chisel 50307180 1-Chisel 50341150 1-Chisel 50314165 1-Chisel 50329105







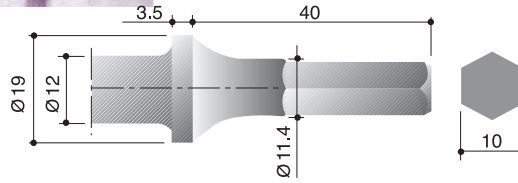



Shank No. 508

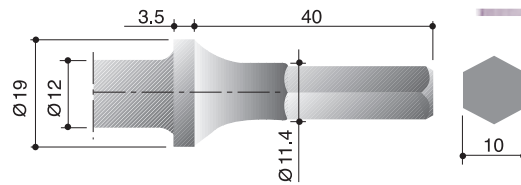

Shank: $\square 10 \times \varnothing 11.4 \times 40 \text{mm}$

Working End	Part No.	Overall Length
		mm
Panel Cutter	50801190	190
		
45mm Wide Chisel	50803185	185
		
33mm Wide Chisel, Bend	50804190	190
		
Spot Weld Breaker	50806180	180
		
33mm Wide Chisel	50812180 50812230	180 230
		
$\varnothing 2.5 \text{mm}$ Taper Punch	50813180	180
		
Moil Point	50815180 50815250	180 250
		

Shank: $\square 10 \times \varnothing 11.40 \times 40 \text{mm}$

Working End	Part No.	Overall Length
		mm
20mm Flat Chisel 	50818125	125
	50818180	180
	50818200	200
	50818250	250
	50818350	350
	50818450	450
Single Blade Panel Cutter 	50822125	125
	50822145	145
Claw Ripper & Panel Cutter 	50823135	135
	50823180	180
50mm Wide Chisel 	50827180	180
50mm Wide Chisel, Bend 	50828180	180



Shank No. 186

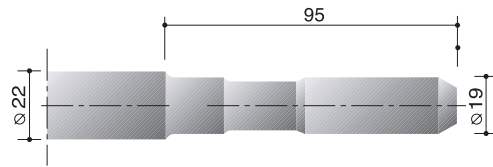



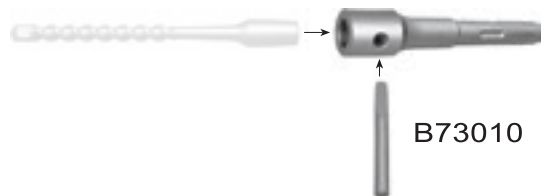

Shank: $\varnothing 19 \times 95 \text{mm}$

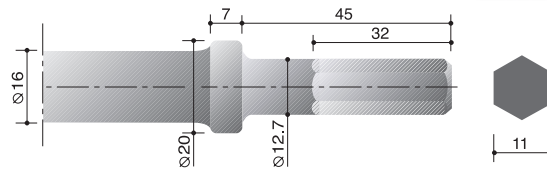
Working End	Part No.	Overall Length
		mm
Moil Point	18601255 18601300 18601380	255 300 380
Flat Chisel	18602255 18602300 18602380	255 300 380
50mm Wide Chisel	18603300	300
75mm Wide Chisel	18604300	300
K-Taper Drill Holder	24601160	160
Snap Lock Adaptor for SDS-Plus Drill Bits	24602220	220



Shank: $\square 11 \times \varnothing 12.7 \times 45 \text{ mm}$







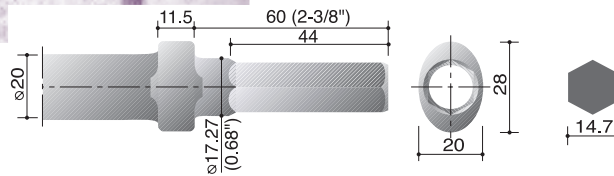

Working End	Part No.	Overall Length
		mm
Moil Point	16401220	220
		
Flat Chisel	16402220	220
		
50mm Wide Chisel	16403220	220
		
50mm Wide Chisel, Bend	16404220	220
		











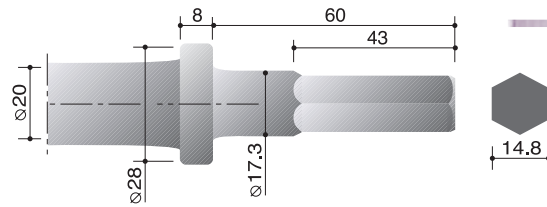



Shank No. 127



Shank: $\varnothing 14.7(0.58") \times \varnothing 17.27(0.68") \times 60\text{mm}(2-3/8")$ with Oval Collar

Working End	Part No.	Overall Length
		mm
Moil Point 	12701230	230
	12701260	260
	12701305	305
	12701460	460
	12701510	510
Flat Chisel 	12702230	230
	12702260	260
	12702305	305
	12702460	460
	12702510	510
32mm Wide Chisel 	12703230	230
	12703305	305
40mm Wide Chisel 	12704230	230
50mm Wide Chisel 	12705230	230
	12705305	305
	12705460	460
75mm Wide Chisel 	12706230	230
	12706300	300
	12706450	450
45mm Bushing Tool 	12708260	260
Ground Rod Driver 3/4" 	12709250	250

Shank: $\square 14.8 \times \varnothing 17.30 \times 60 \text{mm}$

Working End	Part No.	Overall Length
		mm
Moil Point 	12301250	250
	12301300	300
	12301380	380
	12301450	450
	12301600	600
Flat Chisel 	12302300	300
	12302450	450
	12302600	600
25mm Wide Chisel 	12303250	250
	12303300	300
	12303350	350
	12303380	380
	12303450	450
	12303600	600
50mm Wide Chisel 	12304260	260
50mm Wide Chisel, Bend 	12305260	260
60mm Wide Chisel 	12306260	260
60mm Wide Chisel, Bend 	12307260	260
95mm Wide Chisel 	12308270	270
95mm Wide Chisel, Bend 	12309270	270
Adaptor for Floor Scraper 	12310200	200
35mm Slotting Tool with Carbide 	12311200	200
	12311280	280





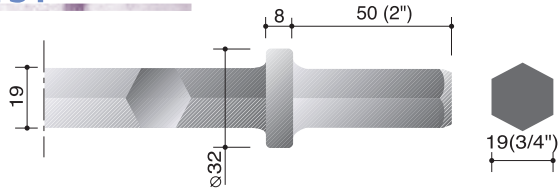



Shank No. 131

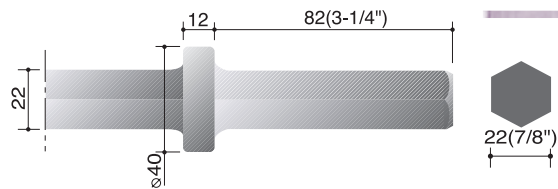

Shank: $\hexagon 19 \times 50 \text{mm}$

Working End	Part No.	Overall Length
		mm
Moil Point	13101300	300
	13101500	500
Flat Chisel	13102300	300
	13102325	325
	13102400	400
	13102500	500
60mm Wide Chisel	13105300	300
	13105600	600
60mm Wide Chisel, Bend	13106300	300
Adaptor for Floor Scraper	13110300	300

Shank: \varnothing 22x82mm





Working End	Part No.	Overall Length
		mm
Moil Point 	14001370	370
	14001440	440
	14001465	465
	14001540	540
	14001600	600
Flat Chisel 	14002370	370
	14002440	440
	14002465	465
	14002485	485
	14002540	540
14002600	600	
75mm Wide Chisel 	14003445	445
	14003535	535
60mm Digging Chisel 	14004450	450
140mm Clay Spade 	14005510	510
125mm Asphalt Cutter 	14006375	375

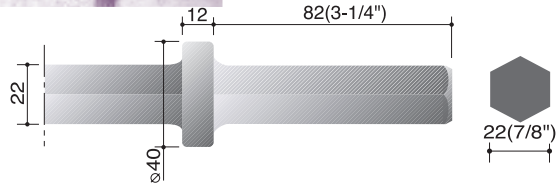







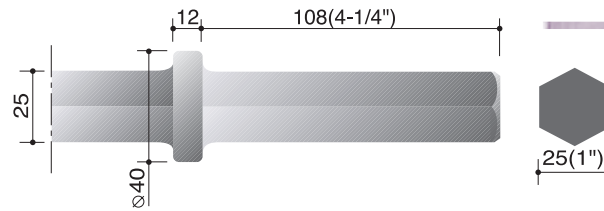

Shank No. 140



Shank: \diamond 22x82mm

Working End	Part No.	Overall Length
		mm
80mm Tie Tamper 	14007720	720
75mm Digging Chisel 	14008520	520
Adaptor for E39 Tamper Plate 	14010400	400
Adaptor for Floor Scraper 	14012290 14012400	290 400

Shank: \varnothing 25x108mm







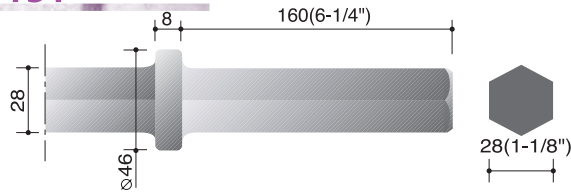



Working End	Part No.	Overall Length
		mm
Moil Point 	14601465	465
	14601490	490
	14601510	510
	14601565	565
Flat Chisel 	14602465	465
	14602490	490
	14602510	510
	14602565	565
75mm Wide Chisel 	14603465	465
	14603565	565
140mm Clay Spade 	14605530	530
125mm Asphalt Cutter 	14606400	400
80mm Tie Tamper 	14607720	720
75mm Digging Chisel 	14609520	520
Adaptor for E38 Tamper Plate 	14610400	400











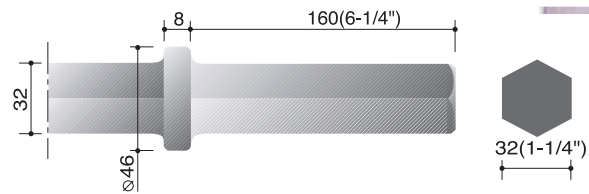



Shank No. 151



Shank: \odot 28x160mm

Working End	Part No.	Overall Length
		mm
Moil Point 	15101510	510
	15101535	535
	15101555	555
	15101610	610
	15101755	755
Flat Chisel 	15102510	510
	15102535	535
	15102555	555
	15102610	610
	15102755	755
75mm Wide Chisel 	15103510	510
Adaptor for Floor Scraper 	15104400	400
140mm Clay Spade 	15105570	570
135mm Pointed Spade 	15106550	550
125mm Asphalt Cutter 	15107445	445
125mm Asphalt Cutter, curved edge 	15109500	500
75mm Digging Chisel 	15110520	520
Adaptor for E38 Tamper Plate 	15111400	400

Shank: \square 32x160mm

Working End	Part No.	Overall Length
		mm
Moil Point 	15501510	510
	15501535	535
	15501555	555
	15501610	610
Flat Chisel 	15502510	510
	15502555	555
	15502610	610
75mm Wide Chisel 	15503610	610
Adaptor for Floor Scraper 	15504400	400
140mm Clay Spade 	15505570	570
135mm Pointed Spade 	15506550	550
125mm Asphalt Cutter 	15507445	445
80mm Tie Tamper 	15508720	720
125mm Asphalt Cutter, curved edge 	15509500	500
75mm Digging Chisel 	15510520	520
Adaptor for E38 Tamper Plate 	15511400	400



Pneumatic Hammer Cross Reference Guide

Hammer Manufacturer	Shank No.	To suit Hammer Models	Page
Airmatic	131 140 146	K3, K4, K5, MS25, PL5 MP8, MP10, MP10/A, PL9 DA200, DA200/S, DE170, DE170/S, DL140, DL140/S, DL16, DP12, DP13, DP13/C	PH-11 PH-12~PH-13 PH-14
Atlas Copco	131 140 146 151 155	TEX3 TEX8H, TEX8HS, TEX11DC, TEX11DCS, TEX11DK, TEX11DKS, TEX11TK, TEX11TKS TEX21, TEX21S, TEX26E TEX20, TEX21, TEX21S, TEX22, TEX23E, TEX31, TEX31S, TEX40, TEX41, TEX41S TEX30, TEX31, TEX31S, TEX32, TEX40, TEX41, TEX41S, TEX42, TEX50	PH-11 PH-12~PH-13 PH-14 PH-15 PH-16
Bohler	131 140 146 151 155	BH5 A7FK, PF67, PH80 A7, U9, U10, U12, B100, B220 B220, B280, BN26 B220, B280, BA26, BN26	PH-11 PH-12~PH-13 PH-14 PH-15 PH-16
Bottarini	140 146 151 155	BD9, BD12 BD12, BD15, BD18 BD20, BD22, BD25, BD34 BD20, BD22, BD25, BD34	PH-12~PH-13 PH-14 PH-15 PH-16
CompAir	140 146 151 155	CD5, CD7, DP7T RB444, ZITEC20 RB555, RB666, RB777, ZITEC27 RB555, RB666, RB777, ZITEC27	PH-12~PH-13 PH-14 PH-15 PH-16
Demag	140 146 155	BMB58, BHB62, P13K, PK8, PK8S, PK8SS, PK12, PK12S, PK12SS, PS17, SP40/1, SP50/1, SP50/1S, SP50/1SB, SP60/1S, SP60/1S, SPF6011 BAK18, P22, PK18, PK18S, PK18SS, PK22, PK22S BAJ25, BAK26, BAK38	PH-12~PH-13 PH-14 PH-16
Flottmann	146 155	CB20, CD25, CD18, CD20, CD25 CB25, CD30, CD32, CD35, CL35/1A	PH-14 PH-16
Frohlich & Klupfel	140 146 155	K7K, SKA9, SKA12, SP9, SP12 FK230.6 K35D	PH-12~PH-13 PH-14 PH-16
Fuji	123	FC-1Z ~ 4Z Hex Shank	PH-10
Hausherr	146	H15	PH-14
Ingersoll Rand	131 140 146 151 155	PH3 93A1, 93A4, 93LA1, 95A1, 95LA1, JH40 59LC3, 95LA3, BR20S, JH40 BR20S, BR30S, BR40S BR20S, BR40S	PH-11 PH-12~PH-13 PH-14 PH-15 PH-16
Irmer & Elze	155	AH57M, AH5712	PH-16
Kawasaki	164	NC0S	PH-08
Kent / Air-Ram	146	PC17, PC18, PC19	PH-14
Krupp	131 140 146 151 155	326, 339-1 216, 226-2, 226-3, 236-2, 236-3, 246-3 231, 231-2, 241 251, 256-1, 256-3, 261 251, 256, 261	PH-11 PH-12~PH-13 PH-14 PH-15 PH-16
Lifton	146	LH16, LH24, LH27	PH-14

Pneumatic Hammer Cross Reference Guide

Hammer Manufacturer	Shank No.	To suit Hammer Models	Page
Maco-Meudon	123 131 140 146 151 155	B3D, SK6 PL39, SK5 MP8, MP9 MK15S, MK15SS, MK20, APB12, CB42/A MK20S, MK20SS, MK30SS, MK35S, CB71 MK20S, MK20SS, MK30SS, MK35S, CB91, CB96	PH-10 PH-11 PH-12~PH-13 PH-14 PH-15 PH-16
Mannesmann-Demag	146 155	P22, PK18S, PK22S P305, P33	PH-14 PH-16
Martillos	140 151	FLH SBR-H	PH-12~PH-13 PH-15
Maruzen Kogyo	146	MHB16	PH-14
Montabert	131 140 146 151 155	MCF3, MCF5, TG3, TG5 T11, T11E, T18, T18E, TG9 ALPHA20, BBH10, BBH13, T11, T11E, T18, T18E, TG9 ALPHA20, DELTA20S2, DELTA30S2 DELTA20S2, DELTA35S2, BBH31, BBH36	PH-11 PH-12~PH-13 PH-14 PH-15 PH-16
NPK	123	AA-1ASP, AA-2SP, AA-3SP, AA-4SP, NC-1SP, NC-2SP, NC-3ASP, NC-4SP	PH-10
PERMON	140 146 155	BKA15, SK9-6, SK9-6A, SKA10D, SKA10DZ, SKA12D, SKA12DZ, SK13D, SK13DZ BKA21, VK22, VK29, VKS29, VKS45 BKA30	PH-12~PH-13 PH-14 PH-16
Premag	140 146 151 155 186	CP111, CP14, CP22, CP222, FL22 CP111, CP1210 CP117, CP1230, CP123S, CP1240 CP117, CP123, CP123S, CP124 CP9F	PH-12~PH-13 PH-14 PH-15 PH-16 PH-07
Rockair	146	BV30	PH-14
Sclaverano	131 140	SG45 SG24, SGD17, SGD18, SGD230	PH-11 PH-12~PH-13
SIG	140 146 151 155	PLA10/03 PLA13, PLA17, PLA24/03 PLA24/01, PLA35/01 PLA24/2, PLA35/2	PH-12~PH-13 PH-14 PH-15 PH-16
Spit	140 146 151 155	72703 73601 73702, 73803 73702, 73803	PH-12~PH-13 PH-14 PH-15 PH-16
Stanley	140	45, BR45, HD20, HD45, SK58110, SK58120	PH-12~PH-13
SULLAIR	140 146	MCD-30, MPB-30A, MRD-30, MRD-40, MRD-50, MTD-30 MCD-30, MPB-30A, MPB-35B, MRD-40, MRD-50, MTD-30	PH-12~PH-13 PH-14
Thor	140 146 151 155	14D, 15D, 16D, 17, 18, 38 20, 21 24, 125, 234, 254 24, 125, 234	PH-12~PH-13 PH-14 PH-15 PH-16
Toku	123	AA-1.3B, AA-3B, AHR-3B	PH-10
Vistarini	140 146 151 155	VD9P, VD9PK, VD12PTK, VD15N, VP12PK VD15N, VD18N VD20, VD22N, VD28, VD28N, VD34, VD34N VD22, VD28, VD28N, VD34, VD34N	PH-12~PH-13 PH-14 PH-15 PH-16
Wacker	140	LH20	PH-12~PH-13
	127	U.S. Navy Standard Chipping Hammer	PH-09



impact tools pty ltd
2-115 hayward avenue, torrensville, sa 5031

phone: 1300 103 104
fax: 1300 103 105
e-mail: sales@impacttools.com.au
web: www.impacttools.com.au

No. CC09CH

May 16. 1000